

Fowler high-precision Toolmaker Vises have solid bodies of one-piece steel construction. Bodies and jaws carburized & hardened to RC58-62. All vises are ground flat, square and parallel within .0002" to .0003".

Due to the precise design of our vises, the jaw is pulled into the base at approximately 45 to 60 degrees. This ensures maximum holding power with superior hold-down force on the jaw to eliminate tilting and lifting.

The angled center channel allows a greater jaw capacity than competitive brands. The jaw opening can be changed without removing the vise from the work surface. Toolmaker vises bolt directly to sine plates and compound sine plates of the same series without clamps and with little or no indicating. End pockets on all models easily clamp to machine table or fixture.

Special Features—No. 57-228-237:

- Ground vertical and horizontal vees inside face of jaws hold round workpieces.
- Ground vees in top of jaws and steps on inside faces of jaw easily hold round or small parts. Two hold-down clamps included with this model for use in conjunction w/top vees.
- Can be bolted to #57-470-444 angle plate.
- Can be bolted to #57-374-002 and #57-375-001 sine plates.

Special Features—No. 57-228-411:

- Additional side slots for further mounting possibilities.
- Can be bolted to #57-374-003, 004 and #57-375-002 sine plates.
- Can be bolted to #57-470-546 angle plate.



Order No.	Dimensions	Capacity	Jaw Height
57-228-237	7 ¹ / ₂ " x 3" x 2 ⁵ / ₈ "	5"	1 ⁵ / ₁₆ "
57-228-411	11" x 4" x 3"	7"	1 ⁷ / ₁₆ "

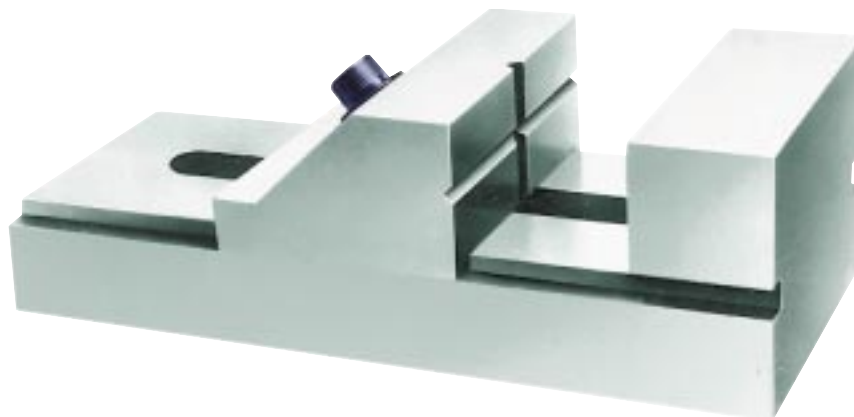

▲ Toolmaker Vise No. 52-466-222.

Fowler's high accuracy Toolmaker Vises make precision holding possible for inspection, precision jig boring, milling and grinding.

Special Features- No. 52-466-222:

- All surfaces hardened and precision ground square and parallel to an accuracy of .0004".
- Has ground slots in sliding jaw.
- Clamping holes are provided.
- Moveable jaw lock includes insertable pin.
- Base and front jaw are one piece all steel construction and case hardened.
- Holes and locking set screw provide adjustable positions. Includes Allen locking wrench.

Special Features- No. 52-466-333:

- All surfaces hardened and precision ground square and parallel within .0005".
- Has ground "V" way in sliding jaw.
- Clamping slots are provided.
- Holes and locking set screw for adjustable positions. Base and front jaw are one piece all steel construction and case hardened.



▲ Toolmaker Vise No. 52-466-000.

Special Features- No. 52-466-000:

- Economy style toolmaker vise.
- Features solid base and front jaw construction. Accuracy to .0006".
- Jaws are not removable.
- Clamping slots on the bottom of the base easily affix to angle plates, etc.



Order No.	Jaw Size	Maximum Opening	Dimensions
52-466-000	2 ³ / ₈ "	2 ³ / ₁₆ "	1 ³ / ₄ " x 2 ³ / ₈ " x 4 ³ / ₈ "
52-466-222	1 ⁷ / ₈ "	2 ⁷ / ₈ "	1 ⁷ / ₈ " x 1 ⁷ / ₈ " x 6"
52-466-333	3"	3 ³ / ₄ "	2 ¹ / ₂ " x 3" x 7"