

INTRODUCTION

Thank you for selecting the DC-525/525H Digital Linear Gauge. To ensure that you get the most out of this instrument, we recommend that you read and follow the instructions in this manual carefully.

In Section 3. MEASUREMENT METHOD, the fundamental operations of the normal measurement function are explained. For operations of the preset and absolute functions, see Sections 4 and 5.

FEATURES

- With the same size body as a standard analog dial gauge (the outer diameter is 52), the compact, direct-reading DC-525/525H digital gauge features a measurements stroke of 0 to 25 mm.
- Any position can be set as the zero point. A direction switch allows the increment direction (direction of positive displacement) to be set.
- The instrument can be powered from AC line power or the built-in rechargeable battery (8-hour continuous operation on a full charge).
- Display mode can be switched between maximum value, minimum value and range (maximum to minimum).
- The linear gauge design provides a high degree of ruggedness with extremely stable accuracy.
- To satisfy an even wider variety of applications, the new preset and absolute measurement functions are provided.

OPERATING PRECAUTIONS

- When using the DC-525/525H for the first time, make sure that it is fully charged (full charge requires 16 hours; see page 10), and press the RESET switch and POWER switch simultaneously to perform a system reset. If the battery is left unused for a long period, it will self-discharge.
- If the DC-525/525H is powered on again after several months have elapsed, fully recharge it then perform a system reset.
- If the display doesn't indicate 0.0000 mm when the power is turned on, press the RESET switch and POWER switch simultaneously to perform a system reset.

- The interface between the spindle and the bearing is precisely machined, so no lateral force (maximum allowable lateral pressure: 100g) or torsional force should be applied to the spindle. Nor should the stem be squeezed more than necessary.
- Oil and dust are detrimental to the spindle. Do not oil it or touch it. The spindle will not more smoothly if oil or dust are permitted to accumulate. To remove a stain on the spindle, wipe it off with a piece of soft cloth slightly dampened with alcohol.
- Since the gauge is assembled from high-precision components, do not treat it roughly or attempt to disassemble it yourself.

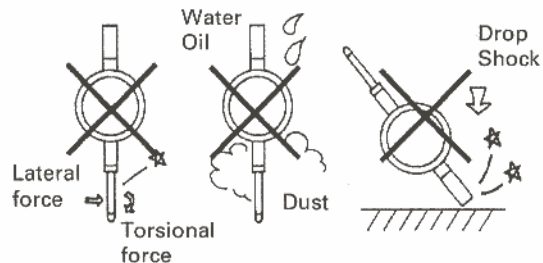
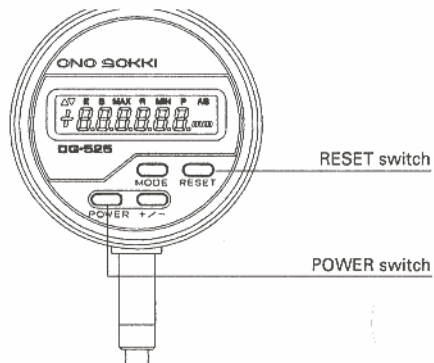

TABLE OF CONTENTS

1. NAMES AND FUNCTIONS OF PARTS	1
1.1 NAMES OF PARTS	1
1.2 LCD DISPLAY SECTION	2
1.3 SWITCHES	4
2. MOUNTING METHOD	7
2.1 MOUNTING TO A FIXTURE	7
2.2 CONNECTION OF THE FINGER LIFTER	9
2.3 REPLACING CONTACT TIP	9
3. MEASUREMENT METHOD	10
3.1 POWER SUPPLY CONNECTION	10
3.2 ZERO RESET	12
3.3 SELECTING THE INCREMENT DIRECTION	12
3.4 MAX-MIN MEASUREMENT MODES	13
3.5 OUTPUT SPECIFICATIONS	14
3.6 SPINDLE MOVEMENT	17
4. PRESET FUNCTION	18
4.1 MEASUREMENT METHOD	18
4.2 SETTING METHOD	20
5. ABSOLUTE FUNCTION	22
5.1 MEASUREMENT METHOD	22
6. MAINTENANCE	24
7. SPECIFICATIONS	25
OUTER DIMENSIONS	26

1. NAMES AND FUNCTIONS OF PARTS

1.1 NAMES OF PARTS

- ① Power Input Connector
- ② LCD Display Section
- ③ Mode Switch
- ④ Power Switch
- ⑤ Direction Switch
- ⑥ Measurement Contact Tip
- ⑦ Output Connector
- ⑧ Reset Switch
- ⑨ Finger lifter
- ⑩ Cap
- ⑪ Stem
- ⑫ Spindle
- ⑬ Mounting Lug Back

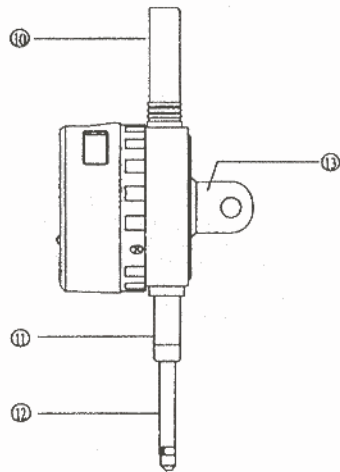
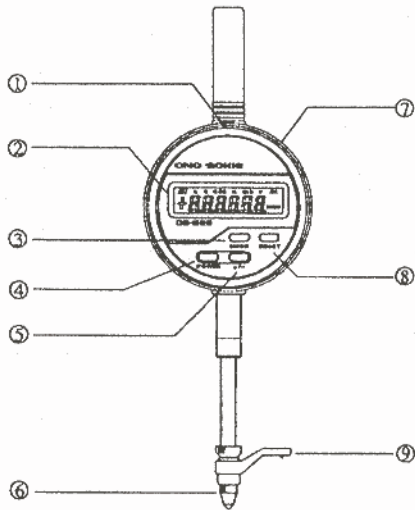

1.2 LCD DISPLAY SECTION

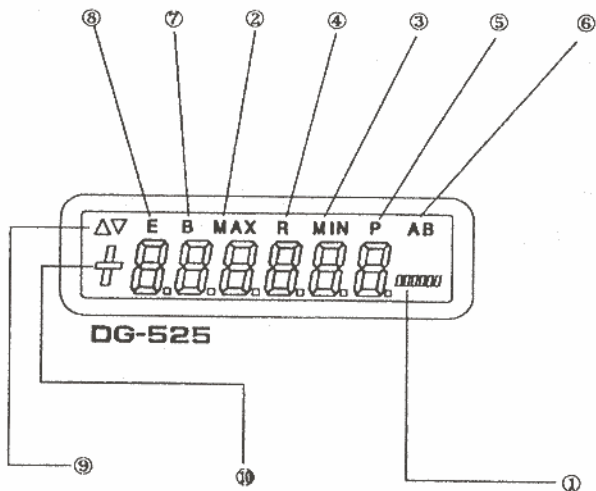

- ① mm : Indicates display of a measurement value in mm units. This unit sign is not displayed during the preset value setting procedure.
- ② MAX : (maximum)
Indicates maximum display mode. The displayed number is the maximum value measured so far; it will not change unless the measured input value exceeds it.
- ③ MIN : (minimum)
Indicates minimum display mode. The displayed number is the minimum value measured so far; it will not change unless the measured input value drops below it.
- ④ R : (range)
Indicates range mode: the range between cumulative maximum and minimum values is displayed.
- ⑤ P : (preset)
Indicates that the preset function has been selected. A flashing "P" indicates that the preset setting procedure is in progress.
- ⑥ AB : (absolute)
Indicates that the absolute function has been selected. The spindle position when the power is switched on is taken as the absolute zero point.

- ⑦ B : (battery)
Indicates that the battery voltage has fallen below a set limit. When the "B" appears in the display, it is time to recharge the battery or switch to using an AC power supply.
- ⑧ E : (error)
The error display indicates that the spindle has been moved faster than the allowable limit, a circumstance which may cause measurement error. Should the "E" appear in the display, turn the power switch off to cancel the error, then turn the power back on to begin measurement again.
- ⑨ ▲ : Indicates the increment direction. Measured value increases as the spindle is pushed in.
- ▼ : Indicates the increment direction. Measured value decreases as the spindle is pushed in.
- ⑩ +(-) : Indicates that the measured value is positive (negative). For a measured value of 0, no sign is indicated.

1.3 SWITCHES

(1) Names and Functions of Switches

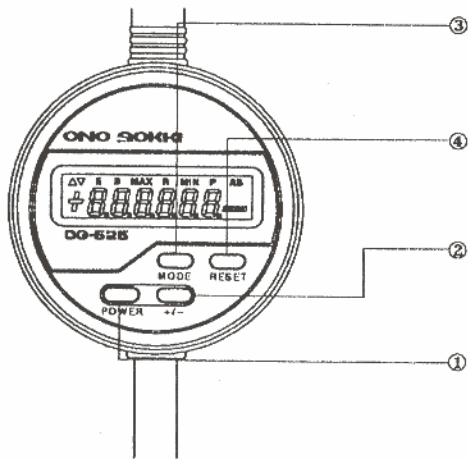

① POWER : Power switch

When the POWER switch is pressed, the DC-525/525H turns on and measurement is possible.

② +/- : Direction switch

Selects whether the measured value is incremented or decremented as the spindle is pushed in.

③ MODE : Mode switch

The display mode can be cyclically changed through the normal, maximum, minimum and range modes.

This switch can also be used to change the measurement function.

(See Section 4. PRESET FUNCTION for more details.)

④ RESET : Reset switch

When pressed briefly, the display value is reset to zero.

This switch can also be used to change the measurement function.

(See Section 4. PRESET FUNCTION and Section 5. ABSOLUTE FUNCTION for more details.)

(2) Switch Operation

The MODE switch and RESET switch have two functions, depending on how long they are pressed.

To change the measurement function, press and hold these switches for about two seconds.

○ Press the switch briefly and release.

● Press the switch and hold for about two seconds, until the display changes.

(3) Switch Functions Within Each Measurement Function

○ : Press briefly and release

● : Press and hold for about 2 seconds

Function \ Switch	POWER	RESET	MODE	+/-
Normal measurement	○ : Turn on/off the power. (Reset E error)	○ : Zero reset Reset the maximum, minimum and range values. ● : Go to AB measurement.	○ : Change to the maximum, minimum or range measurement mode. ● : Go to P measurement.	○ : Change the increment direction (invalid during maximum, minimum and range modes).
Absolute measurement	○ : Turn off the power. (Reset the absolute zero point)	○ : Return to normal measurement.	—————	(The increment direction is fixed at).
Preset measurement	○ : Turn off the power.	○ : Reset to the preset value. Reset the maximum, minimum and range values. ● : Go to normal measurement.	○ : Change to the maximum, minimum or range measurement mode. ● : Go to P setting.	—————
Preset value setting	○ : Turn off the power.	○ : Leave P setting and return to P measurement.	○ : Cycle digit value from 0 thru 9. ● : Set the displayed digit value and move the flashing point sequentially to the right. After setting, to P measurement.	—————

(4) Switch Operations for Changing the Measurement Function

 : Press briefly and release

 : Press and hold for about 2 seconds

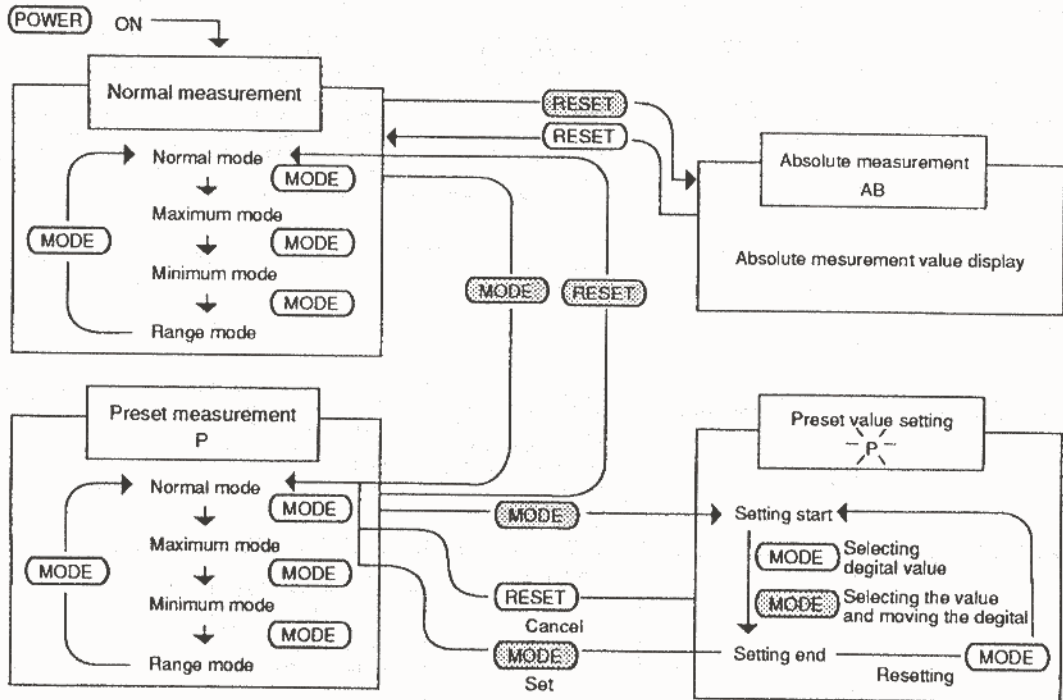

2. MOUNTING METHOD

2.1 MOUNTING TO A FIXTURE

There are two methods of holding the instrument. The mounting fixture should be stiff with no deflection.

(1) Bolting to the Lug

Pass a bolt through the 6.5 ± 0.1 mm dia. hole in the lug on the back cover and fasten it tightly to the mounting fixture.

If it is insufficiently tight, the gauge might pivot around the bolt. Therefore, it is recommended to use a flat washer and a spring washer on both sides.

The lug can be rotated by 90° by removing the four screws on the back cover.

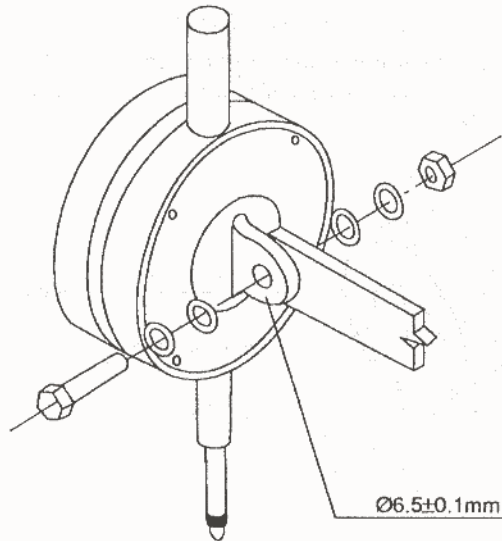

(2) Grasping the Stem

The stem has a diameter of $100-0.03$.

It is recommended to use the optional gauge stand (ST series). When making another stand, consult the drawing below.

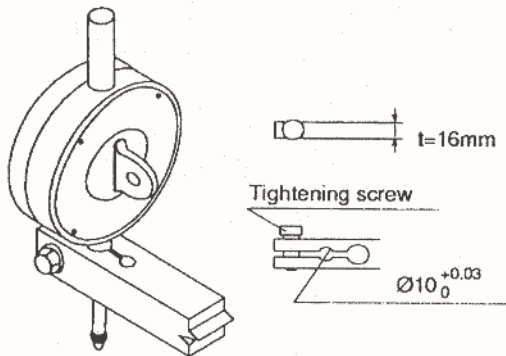

CAUTION Care should be taken not to apply excessive force to the stem.

(3) Precautions for Mounting

When mounting to a fixture, always be sure that the gauge is mounted so that the direction of spindle movement and the longitudinal axis of the object being measured agree, and the spindle makes contact at the proper position.

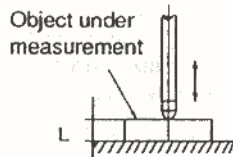

Direction of spindle movement should agree with L axis.

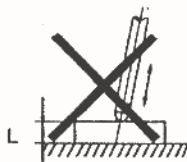

If, as shown above, the direction of spindle movement and axis L do not agree, error will occur in measured values.

2.2 CONNECTION OF THE FINGER LIFTER

The accessory finger lifter can be inserted between the lifter screw and the end of the spindle by removing the contact tip at the end of the spindle as shown in the figure below.

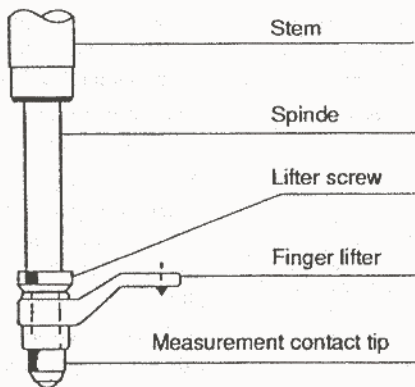

2.3 REPLACING CONTACT TIP

(1) Replacing the Contact Tip

The standard contact tip is attached to the spindle by an M 2.5 screw. Various types of contact tips are available for your selection, depending on the object to be measured and other specific aspects of the application.

To replace the contact tip, wind a rubber band round the spindle, as shown in the figure below, and turn the contact tip while holding the spindle firmly. Take sufficient care not to allow torsional force to be applied to the spindle.

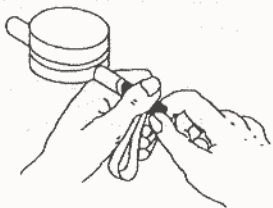

(2) Use of a Flat Contact Tip.

When attaching a flat contact tip to the digital gauge, be sure to keep good parallelism between the tip and reference surface to maintain the measurement accuracy of $10\mu\text{m}$.

3. MEASUREMENT METHOD

3.1 POWER SUPPLY CONNECTION

(1) Connection of the power box (PB-701)

Remove the cover cap from the round connector hole at the top of the gauge and insert the plug of the PB-701. When the PB-701 is connected in this manner, the unit operates on AC line power.

When the PB-701 is not being used, always be sure to replace the cover cap to prevent dust from entering the gauge.

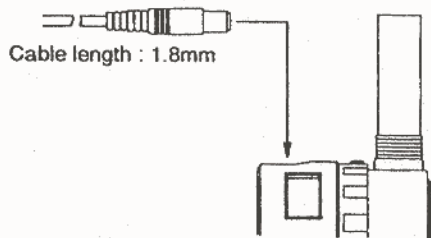

Specifications of PB-701

Input voltage	100/120/220/240 VAC $\pm 10\%$, 50 to 60 Hz
Power consumption	Approx. 4.5VA
Rated output	9 VDC, 300 mA

(2) Battery Operation

In order to recharge the battery, connect the PB-701 to the DC-525/525H and turn the power switch off. The battery will be fully charged in 16 hours. When fully charged, the battery will support continuous operation for 8 hours. Avoid charging for longer than 16 hours.

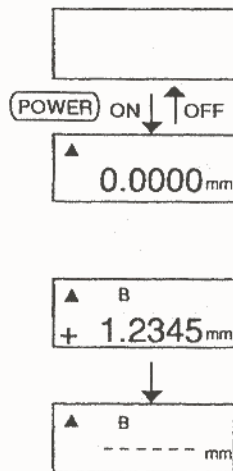

Remove the PB-701 and switch the power on.

When fully charged, the battery will support continuous operation for 8 hours.

When it is not being used, switch the power off.

When the voltage of the internal rechargeable battery falls below a reference level, "B" appears in the LCD display.

With continued use the voltage will drop lower, "... " will appear in the display and the power will be switched off automatically.

If "B" appears, the battery should be recharged with the PB-701, or the DC-525/525H should be run on AC power.

(3) AC Power Operation

Connect the PB-701 and use the instrument with the power switch on. During this time the DC-525/525H will continue to be charged, so that it will not power off even if the power supply from the PB-701 is cut off. Use the POWER switch to turn it off. When the DC-525/525H is to be left unused for a long time, disconnect the PB-701.

(4) When "0.0000 mm" does not appear, even though the power is on

When "B-----" appears in the display, the battery voltage has fallen below a reference level. Charge it by connecting the PB-701.

When the PG-701 is connected and the power switch is on, but the display does not show "0.0000 mm", recharge for several hours and then perform a system reset. The battery may have been over-discharged.

(5) Built-in Battery Life

The instrument contains a built-in Secondary battery, whose capacity deteriorates after repetitive discharge (approx. 300 times).

When its continuously usable time becomes less than half of the new product's, contact your nearest sales representative to change the battery.

● HOW TO PERFORM A SYSTEM RESET.

Press the RESET switch and POWER switch simultaneously.

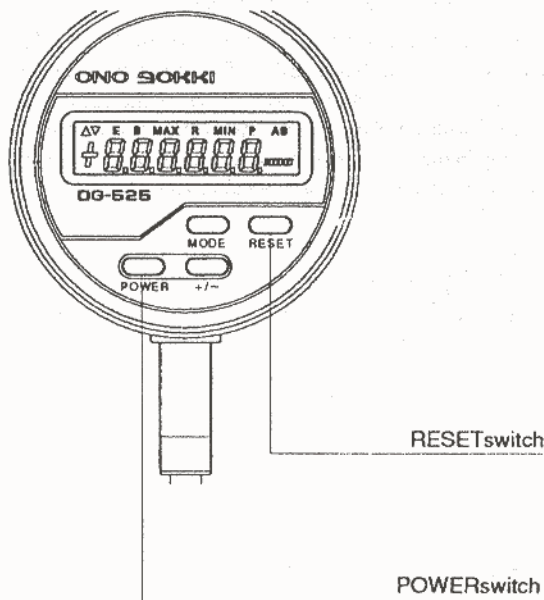

3.2 ZERO RESET

The spindle position at the time when the POWER is switched on, or when the RESET switch is pressed briefly and is released, is taken as 0.0000 mm.

Note, however, that the free-rest position of the spindle, when it is out of contact with the reference surface, cannot be taken as a correct zero point because the spindle is damped with a rubber stopper. Reset the zero point after pushing in the spindle 0.1 mm or more from the free-rest position to avoid inaccurate measurement.

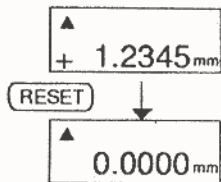

3.3 SELECTING THE INCREMENT DIRECTION

The measured value is incremented or decremented, depending upon the direction of spindle movement.

The direction of increment is indicated by the ▲ or ▼ mark in the display.

▲ : Increment (+ direction) when the spindle is pushed in.

▼ : Decrement (- direction) when the spindle is pushed in.

▲ ▼ can be selected by the direction switch.

 The increment direction is switched each time this switch is pressed.

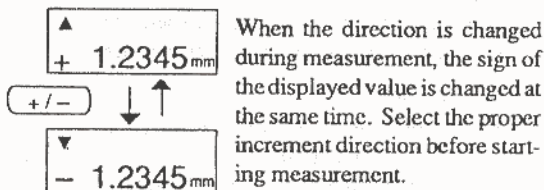

When the direction is changed during measurement, the sign of the displayed value is changed at the same time. Select the proper increment direction before starting measurement.

The selected direction is retained in memory even after the power is turned off.

However, it will be reset to ▲ if you perform a system reset.

3.4 MAX-MIN MEASUREMENT MODES

In the MAX, MIN and R modes, maximum and minimum values are continuously registered, and the peak value is shown in the display. (Since the data sampling period is about 30 ms, if the spindle position changes during that time the true maximum or minimum value may not be read.)

In the normal mode, max. and min. values are not registered.

MODE ○ Press the switch briefly and release.

The display will change in the following sequence: normal mode → MAX mode → MIN mode → R mode → normal mode

(1) Maximum value display

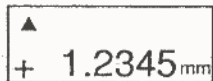

▲
+ 1.2345_{mm}

MODE

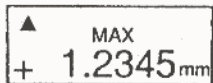

▲
MAX
+ 1.2345_{mm}

When the MODE switch is pressed once in the normal mode, "MAX" appears in the display, indicating that the instrument is now in maximum measurement mode. In this mode, measured values are continuously compared with the cumulative maximum, which is displayed.

(2) Minimum Value Display

When the MODE switch is pressed once in the MAX mode, "MIN" appears in the display, indicating that the instrument is now in minimum measurement mode. In this mode, measured values are continuously compared with the cumulative minimum, which is displayed.

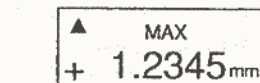

▲
MAX
+ 1.2345_{mm}

MODE



▲
MIN
+ 1.2345_{mm}

MODE

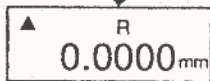

▲
R
0.0000_{mm}

(3) Range (MAX-MIN) Display

When the MODE switch is pressed once in the MIN mode, "R" appears in the display, indicating that the instrument is now in range mode.

MODE



▲
+ 1.2345_{mm}

In this mode, the cumulative maximum and minimum values are internally registered in accordance with spindle movement, and the range value (MAX-MIN) is displayed continuously.

(4) Data Reset

To reset the data, move the spindle to the reference

point and press the RESET switch. When resetting is made in MAX, MIN or R mode, the display shows 0.0000 and measurement begins from this point. The initial maximum and minimum values for MAX, MIN and R modes are the value displayed when MAX mode is first entered from the normal mode.

(In the example at left, initial values are set to +1.2345.)

3.5 OUTPUT SPECIFICATIONS

The DC-525/525H has a serial connector that allows output to be sent to a printer.

(1) Connector Connection

Remove the protective cap from the square hole and insert the connector of the signal cable from the printer into place.

Always switch the power off first, before making the connection.

When output is not required, always keep the connector covered with the protective cap to prevent dust from entering the unit.

(When the cap has been removed, it can be passed over the spindle cap to keep it handy.)

Viewed from the front side

PIN NUMBER	1	2	3	4	5
OUTPUT SIGNAL	SIGNAL COMMON	CLOCK	DATA	RESET	MODE

(2) Output Signal Electrical Characteristics

All output signals are generated by CMOS devices (1 LS TTL load drive capacity)

HIGH ... $V_{OH} > 4.0V$ ($V_{CC} = 4.5V, I_{OH} = -10\mu A$)

LOW ... $V_{OL} < 0.4V$ ($V_{CC} = 4.5V, I_{OL} = 1.8mA$)

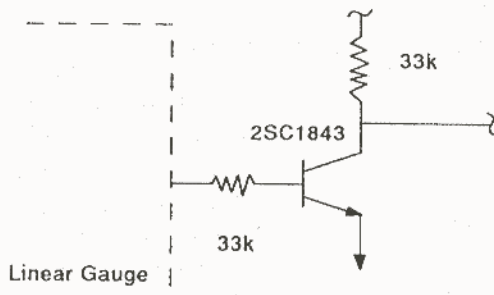

- Main unit connector: 008283-0511-00000
(Manufacturer: Elco (Japan))
- Appropriate connector: 60-8283-3058-15001
(Manufacturer: Elco (Japan))

(3) Output Signal Description

Signal Common

(Pin No.1) :

Common line for all signal lines

Clock (Pin No.2) :

Timing clock for output of four-bit data

Frequency: Approx. 125kHz (refer to the timing diagram)

Data (Pin No.3) :

As shown in the table below, one data value is output in 12 steps, each step consisting of four bits.

Step	Name	2 ³	2 ²	2 ¹	2 ⁰	Description	
1	F _H	1	1	1	1	Step 1 is indicated by F ^H	
2	E _H	1	1	1	1	E ^H indicated that the value is the 6th	
3	10 ⁵ digit data	2 ³	2 ²	2 ¹	2 ⁰	6th digit (10 ⁵)of linear gauge LCD is output	
4	10 ⁴ digit data	2 ³	2 ²	2 ¹	2 ⁰	5th digit (10 ⁴)of linear gauge LCD is output	
5	10 ³ digit data	2 ³	2 ²	2 ¹	2 ⁰	4th digit (10 ³)of linear gauge LCD is output	
6	10 ² digit data	2 ³	2 ²	2 ¹	2 ⁰	3rd digit (10 ²)of linear gauge LCD is output	
7	10 ¹ digit data	2 ³	2 ²	2 ¹	2 ⁰	2nd digit (10 ¹)of linear gauge LCD is output	
8	10 ⁰ digit data	2 ³	2 ²	2 ¹	2 ⁰	1st digit (10 ⁰)of linear gauge LCD is output	
9	Decimal Point	0	0	0		123456.	
		0	0	1		12345.6	
		0	1	1		1234.56	
		0	1	0		123.456	
		1	0	1		12.3456	
		1	0	0		1.23456	
		1	1	1		.123456	
	Sign				0	+ sign	
					1	- sign	
	10	Unit	0	0	0	0	No Unit
			0	0	0	1	m/s
			0	0	1	0	inch/s
0			0	1	1	rps	
0			1	0	0	rpm	
0			1	0	1	inch	
0			1	1	0	mm	
11	Not use		x			Not used	
	MAX			Max		High for maximum display	
	MIN				Min	High for minimum display	
12	END	0	0	0	0	End for output of one value	

Reset (Pin No.4):

When the RESET switch is pressed, output is LOW.
Pin No.1. is signal common.

- RESET switch ON

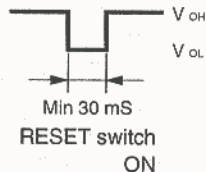

Mode (Pin No.5):

When the MODE switch is pressed, output is LOW.
Pin No.1. is signal common.

- MODE switch ON

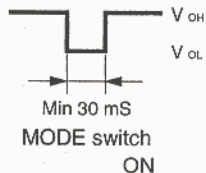

(4) Timing Diagram

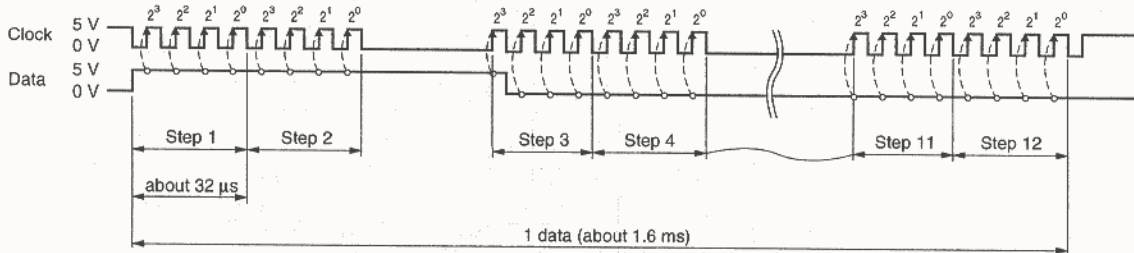

3.6 SPINDLE MOVEMENT

(1) Spindle Speed

The maximum response speed of the DC-525/525H spindle is 300 mm/s (at 20°).

Moving the spindle faster than the allowable limit may cause measurement error.

When "E" appears in the display, temporarily switch off the power to cancel the error status, then begin measurement again.

Ideally, the spindle should be raised and carefully lowered within 1 mm of the object to be measured, then allowed to fall slowly onto its surface.

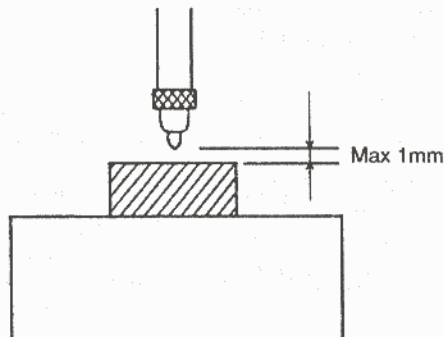

(2) Spindle Lifter

Oil and dust are detrimental to the spindle. If you oil it or touch it, the spindle will not slide smoothly, causing measurement errors of some microns.

So use the accessory finger lifter or move the spindle slowly by holding only the contact tip with your fingers.

(3) Spindle Reference Point

If the spindle is not touching the reference surface, its free rest point cannot be used as a correct zero point because the spindle is damped with a rubber stopper at the end of its range of motion.

The zero point must be taken when the spindle is pushed in.

4. PRESET FUNCTION

This function allows the display to be preset to a specific value, which will be taken as the reference point for subsequent measurement. The maximum value that can be set is 69.9995 mm.

For example, when measuring a part with a size of 50 mm } 10 mm, set the preset value to 50.0000, and then reset the unit using a 50 mm block gauge. Then, measurement (display and output) will proceed in the 40.0000 mm to 60.0000 mm range.

4.1 MEASUREMENT METHOD

(1) Switching to Preset Function

When the power is turned on, the normal measurement function is automatically selected.

The direction switch cannot be used in the preset function.

The counting direction is fixed to the direction set in the normal measurement function.

If the MODE switch is pressed and held for approx. 2 seconds in the normal measurement function, "P" will appear in the display, indicating that the preset function has been selected.

At that time the preset value will be displayed.

(If no value has been set, 0.0000 mm will be displayed.)

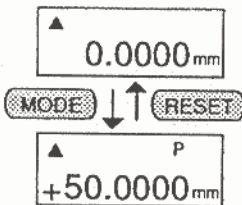

To return to the normal measurement function, press and hold the RESET switch for approx. 2 seconds then release it. The "P" mark will disappear and 0.0000 mm will be shown in the display.

(2) Switch Operation in Preset Function

RESET : ○ Press briefly and release.

The current spindle position is reset to the preset value (0.0000 in R mode).

The measurement values in MAX, MIN and R measurement modes are also reset.

- Press and hold for approx. 2 seconds.

Instrument returns to the normal measurement function.

MODE : ○ Press briefly and release.

Each time the switch is pressed, the mode will change in the following sequence: Normal mode → MAX mode → MIN mode → R mode → Normal mode

- Press and hold for approx. 2 seconds. Then the P mark blinks and the preset value setting function is selected.

POWER : Turns the power off.

When the power is turned on again, the normal measurement function is active.

(3) MAX-MIN measurement modes

Each time the MODE switch is pressed, the mode changes in the following sequence: normal mode → MAX mode → MIN mode → R mode.

Measurement is possible in each mode: MAX, MIN or R.

To reset the measurement value, return the spindle to the reference point and press the RESET switch briefly.

When a reset is performed: in the normal, MAX and MIN modes, the display value is reset to the preset value; in the R mode it is reset to 0.0000.

Basic operation is the same as for the normal measurement function. Refer to page 13.

4.2 SETTING METHOD

(1) Switching to the preset value setting function

If the MODE switch is pressed and held for approx. two seconds in the preset function, the "P" and "+" or "-" sign will blink in the display, indicating that the preset value setting function has been selected.

In this function, the unit indication disappears from the display.

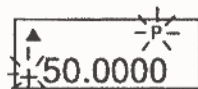
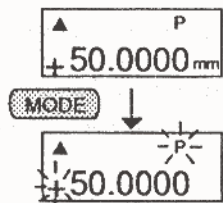

MODE

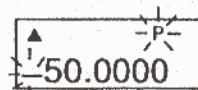

MODE

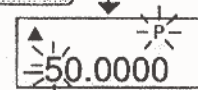

MODE

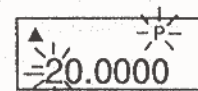

MODE

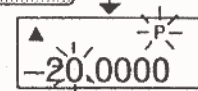

The maximum value that can be set is 6.9995 mm.

It is not possible to set values above this limit.

The RESET switch can be used to return to the preset function.

Press the MODE switch briefly and release, and the sign should toggle between "+" and "-".

When the desired sign appears, press and hold the MODE switch for two seconds.

When this is done, the currently displayed sign will be set, and the blinking part of the display will move one place to the right.

When the digit to be set is blinking, release the MODE switch.

At this point, if the MODE switch is pressed briefly and released, each time it is pressed the digit value will change sequentially from 0 through 9 and return to 0.

(2) Setting the preset (offset) value

The MODE switch is used to set the preset value.

MODE : ○ Press briefly and release to change the sign or a digit value.

● Press and hold for approx. 2 seconds.

Set the currently displayed digit value and move the digit-being-set (blinking) one place to the right.

When the desired value is displayed, press and hold the MODE switch at least two seconds. Repeat this procedure until the desired preset value has been completely set.

(3) End of setting (Returning to preset function)

When the final digit has been set, press and hold the MODE switch for approx. 2 seconds.

When this has been done, only the "P" will blink. At this point, if it is necessary to perform the setting procedure again, press the MODE switch one more time for less than 2 seconds and release.

Once again, the "+" or "-" sign will blink, and the value can be changed. If the set value is ok, press and hold the MODE switch for 2 seconds. The "P" will stop blinking, the mm unit indication will be displayed, and the instrument will return to the preset function.

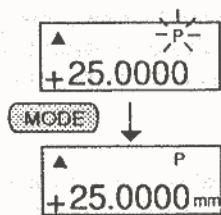

To cancel a partially set value in the middle of the setting procedure, press the RESET switch. The instrument will immediately return to the preset function, without changing the previous preset value.

The preset value is held in memory even when the power is switched off.

However, if a system reset is performed, the preset value is reset to its initial value of 0.000.

5. ABSOLUTE FUNCTION

The spindle position when the power is switched on is taken as the absolute zero point, and from that time forward the absolute function keeps track of displacement from that point. Regardless of the value displayed in the normal measurement function, the absolute displacement can be referred to by switching over to the absolute function. No matter how many times resetting is performed in the normal measurement function, there is no effect on the value maintained by the absolute function. (The absolute function value can be reset only by turning the power off.)

The absolute function is useful when making both relative and absolute measurements.

5.1 MEASUREMENT METHOD

(1) Switching to the Absolute Function

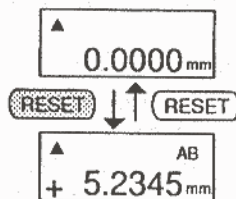

When the power is turned on, the normal measurement function is automatically selected.

When the RESET switch is pressed and held for 2 seconds in the normal measurement function, the AB mark will appear, indicating that the absolute function has been selected.

CAUTION If the RESET switch is pressed for a shorter time and released in the normal measurement function, the only effect will be to reset the display value to zero.

To return to the normal measurement function from the absolute function, press the RESET switch. The instrument will return to the mode active immediately before the absolute function was switched to.

(2) Switch Operation in the Absolute Function

RESET : Returns to the normal measurement function.

POWER : Turns off the power.
To reset the absolute function value to zero, turn the power off and on again.
The direction switch is inoperative in the absolute function.

The counting direction is fixed in the ▲ direction. Therefore, the direction of positive displacement may be the reverse of that in the normal measurement function.

6. MAINTENANCE

- After use, remove dirt from the contact tip and spindle, and put on the accessory cap. Any dirt accumulated on the spindle should be wiped off with a cloth dampened with alcohol.
- If the outer case becomes soiled, wipe it with a dry soft cloth. If the case is badly soiled, wipe it with a cloth slightly wetted with a neutral detergent. Avoid volatile organic solvents like thinners, since such liquids may damage the case.
- If the instrument is not being used, keep the power switch off. If it is not used for a long period, it will self-discharge, so recharge the battery and perform a system reset before using it again.

7. SPECIFICATIONS

Specifications

Measurement range	: 25mm
Resolution	: 0.5 μ m
Indication accuracy	: 1.5 μ m (DG-525) (at 20°C) 1 μ m (DG-525H) (at 20°C)
Maximum response speed	: 300mm/s
Measuring power	: 1.47N (150gf) or less
Display unit	: LCD, 5 digits (with +/- sign)
Data output	: Serial BCD
Power supply	: 100VAC \pm 10%, 50 to 60Hz Secondary battery 8-hour continuous operation on 16-hour full charge
Operating temperature	: +5°C to +40°C
Storage temperature	: -10°C to +55°C
Weight	: Approx.180g

Accessories

- Finger lifter: AA-969
- Power box: PB-701

Options

- Back cover without lug: AA-968
- Lift lever: AA-971
- Release lifter: AA-972
(Used in combination with AA-813 or AA-816
release cable)
- Extension spindles: AA-844/845
- Contact tips
- Gauge stands : ST-011/022/044
(The AA-892 bushing is required when an ST- stand
is used)

OUTER DIMENSIONS

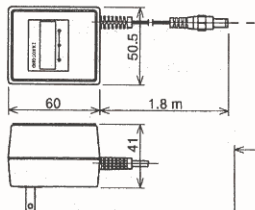
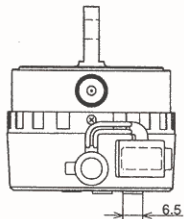

AC adapter: PB-701
(1 : 2)

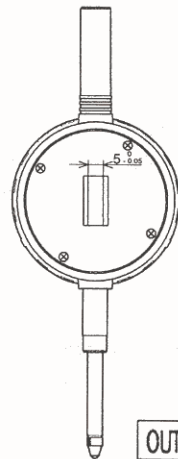
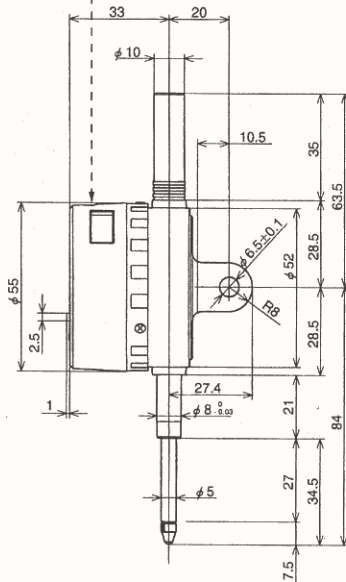
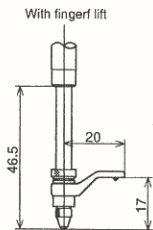
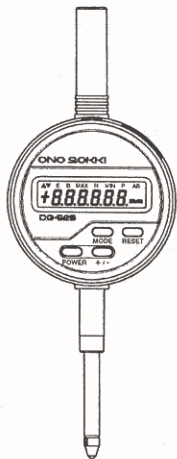

OUT LINE VIEW

