

CONTACT TIPS

AA-889-English measuring contact tip set.AGD 4/48"

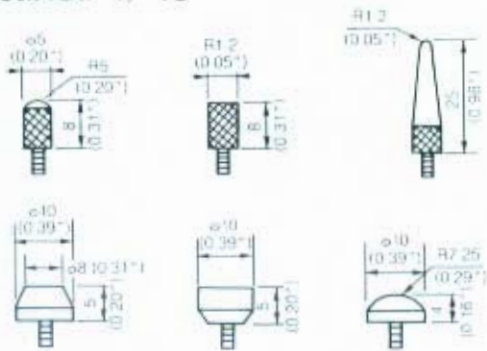

Metric contact tips.ISO M2.5

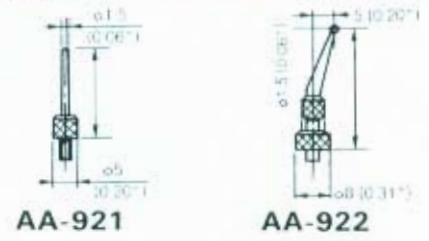
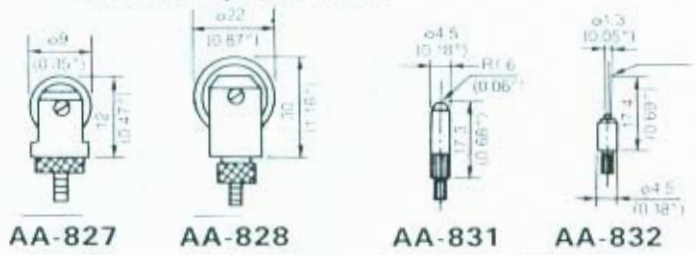

Above tips are also available in metric ISO M2.5.

* English/Metric and Metric/English tip adapters are available for thread conversion.

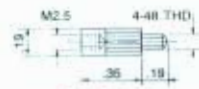

AA-847

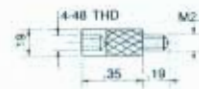

AA-848

Standard ball tips
English Metric



AA-880



AA-820

GAUGE STANDS

ST-022

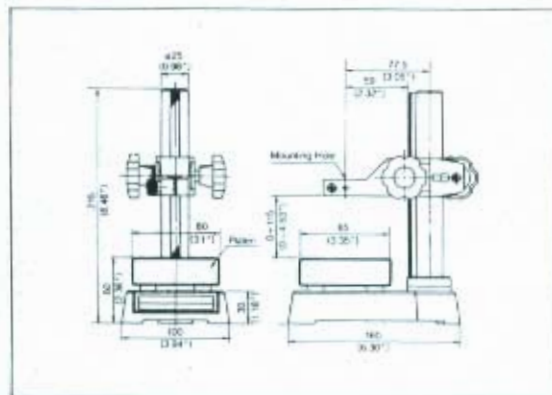

TABLE(WXD)	3.1X3.3" (80X85mm)
BASE(WXD)	3.94X6.3" (100mmX160mm)
VERTICAL MOVEMENT	Rack and Pinion
MEASUREABLE HEIGHT	4.7"(128mm)
APPLICABLE GAUGES	All except GS-1000

ST-044

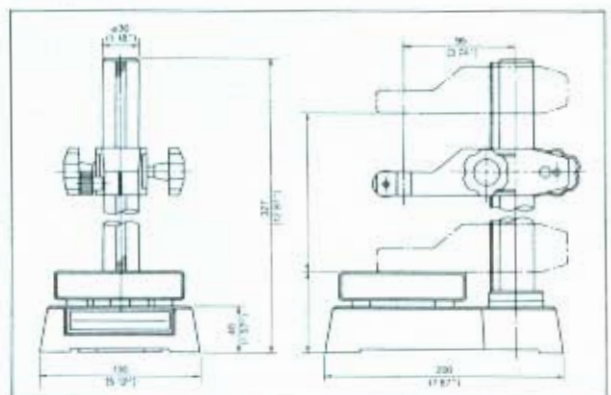

TABLE(WXD)	4.1X4.1" (105X105mm)
BASE(WXD)	5.1X7.8" (130X200mm)
VERTICAL MOVEMENT	Rack and Pinion
MEASUREABLE HEIGHT	9.8"(250mm)
APPLICABLE GAUGES	All gauges.

○ A ceramic base is used to ensure highly precise measurements while eliminating measurement errors caused by the nicks and wear common with stone or metal bases.

Note: A bushing is necessary when using the ST-044 with all gauges except the GS-1000.