

CONTACT TIPS

AA-889-English measuring contact tip set. AGD 4 / 48 "

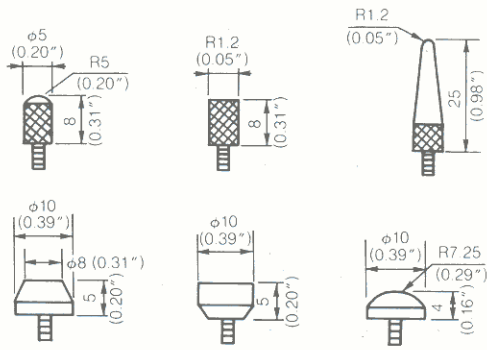

Metric contact tips. ISO M2.5

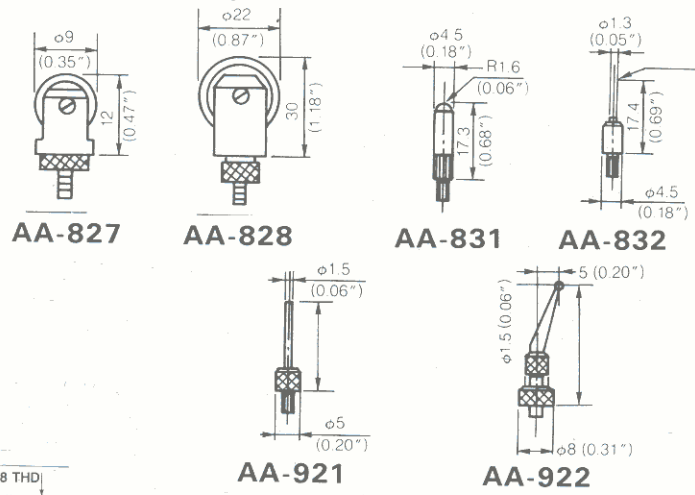

Above tips are also available in metric ISO M2.5.

* English/Metric and Metric/English tip adapters are available for thread conversion.

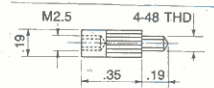

AA-847

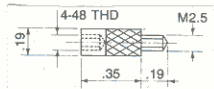

AA-848

Standard ball tips



AA-880



AA-820

GAUGE STANDS

ST-022

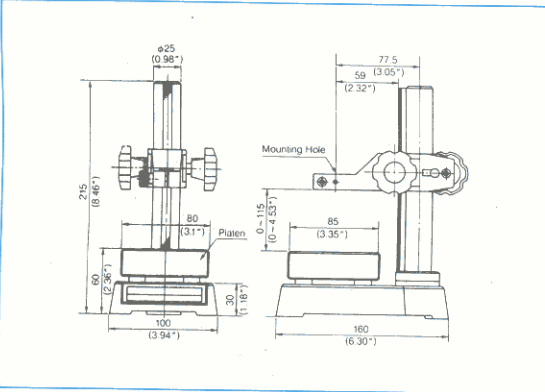

TABLE(WXD)	3.1X3.3" (80X85mm)
BASE(WXD)	3.94X6.3" (100mmX160mm)
VERTICAL MOVEMENT	Rack and Pinion
MEASUREABLE HEIGHT	4.7"(128mm)
APPLICABLE GAUGES	All except GS-1000

ST-044

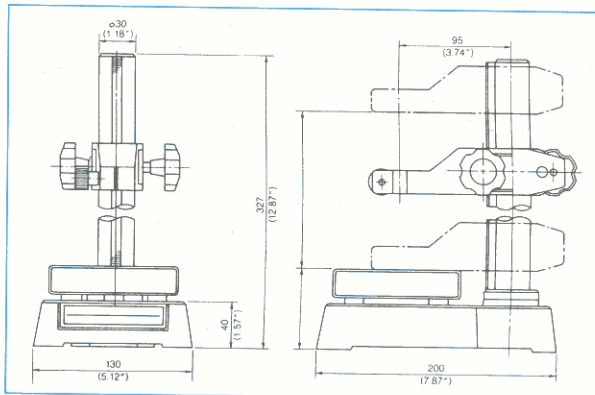

TABLE(WXD)	4.1X4.1" (105X105mm)
BASE(WXD)	5.1X7.8" (130X200mm)
VERTICAL MOVEMENT	Rack and Pinion
MEASUREABLE HEIGHT	9.8"(250mm)
APPLICABLE GAUGES	All gauges.

A ceramic base is used to ensure highly precise measurements while eliminating measurement errors caused by the nicks and wear common with stone or metal bases.

Note: A bushing is necessary when using the ST-044 with all gauges except the GS-1000.

EXTENSION CABLES FOR GS-SERIES SENSORS

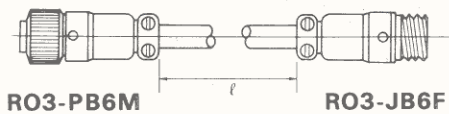

- * Connectors Can be purchased separately.
- * RO3-R6F Panel mount connector also available.

PART	Length ℓ
AA-801	16'53" / 5 Meter
AA-802	32'10" / 10 Meter
AA-803	65'7" / 20 Meter
AA-804	98'5" / 30 Meter

DUST BELLOWS / SPINDLE EXTENSIONS

Dust Bellows		
Part #	Length	Applicable Gauges
AA-4100	13 mm	GS-1513 / GS-1613
AA-4101	30 mm	GS-1530 / GS-1630
AA-854	50 mm	GS-503
AA-841	100 mm	GS-1000

Spindle Extensions		
Part #	Description	Length
AA-844-1	Metric threads 2.5M	20 mm
AA-844	Metric threads 2.5M	30 mm
AA-845	Metric threads 2.5M	50 mm
AA-844A	English threads 4/48"	1.0"
AA-845A	English threads 4/48"	2.0"

OUTPUT CABLES

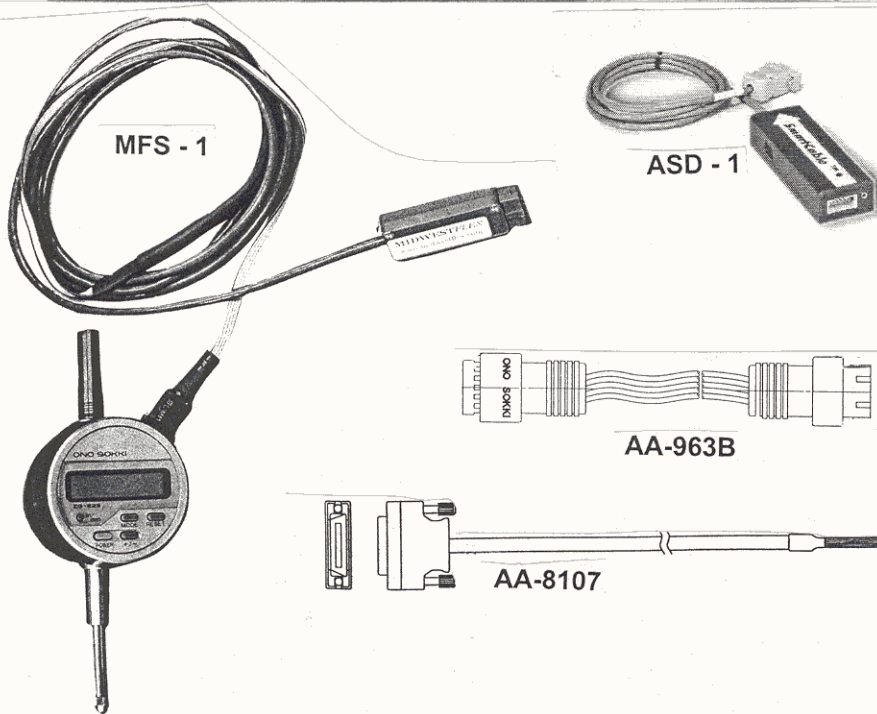

Output Cables			
Part #	Description	Length	Applicable gauges
MFS - 1	Output to MTI	6.0'	EG-225, DG-925, DG-525, DG-3610
ASD - 1	Output to RS-232C	6.0'	EG-225, DG-925, DG-525, DG-3610
AA-963B	Serial BCD output	2.5'	EG-225, DG-925, DG-525, DG-3610
AA-8107	BCD output	10.0'	DG-4120, DG-4240, DG-4280

AIR LIFTERS

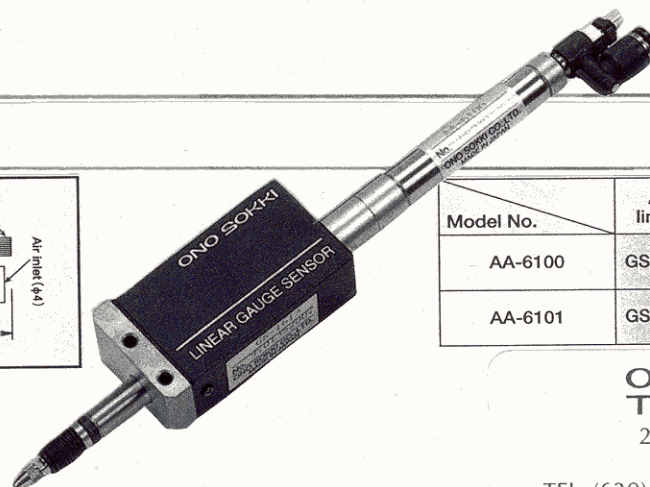
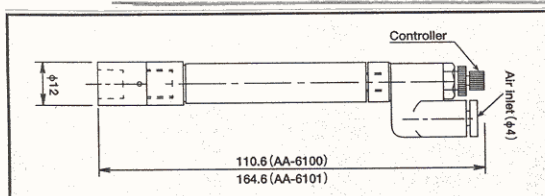

Model No.	Applicable linear gauges	Measurement range (mm)	Air pressure (MPa)
AA-6100	GS-1513A/1613A	0~13	0.25~0.7
AA-6101	GS-1530A/1630A	0~30	0.25~0.7

ONO SOKKI TECHNOLOGY INC.

2171 EXECUTIVE DR., SUITE 400
 ADDISON, ILLINOIS 60101
 TEL: (630) 627-9700 • FAX: (630) 627-0004
 www.onosokki.net • info@onosokki.net