

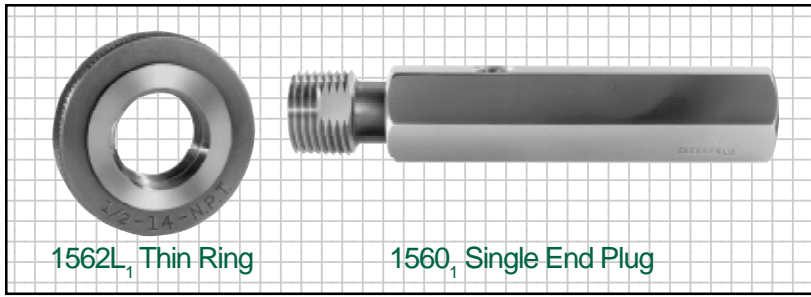

NPT

Inch Sizes

Taper Pipe Gages - NPT



American National Taper Pipe Thread Gages (NPT) are furnished to thread specifications which are in agreement with the National Institute of Standards and Technology Handbook H-28 and to American Gage Design dimensions as shown below. Master and reference gages can be furnished on request.

Plug Dimensions

Ring Dimensions

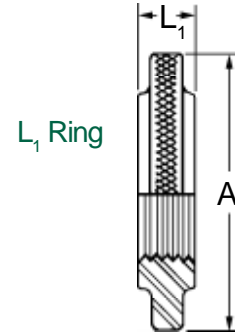
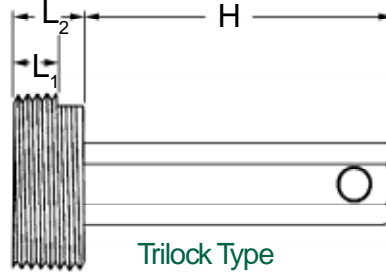
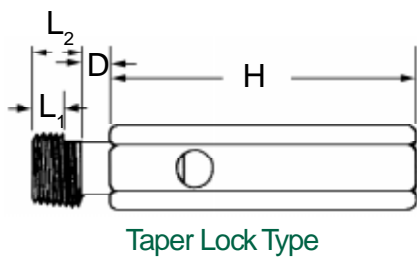

Nominal Size	Length Member			D Taper Lock Only	Handle			
	L ₁ to Notch Tolerance	L ₂ Min.	L ₂ Length		H			
					No.	Hex		
1/16	27	.160	.001	.261	1/4	1	2 3/4	3/8
1/8	27	.1615	.001	.264	1/4	2	3	1/2
1/4	18	.2278	.001	.402	1/4	3	3 1/4	11/16
3/8	18	.240	.001	.408	1/4	3	3 1/4	11/16
1/2	14	.320	.001	.534	5/16	4	3 5/8	7/8
3/4	14	.339	.001	.546	5/16	4	3 5/8	7/8
1	11 1/2	.400	.001	.683	3/8	5	4	1
1 1/4	11 1/2	.420	.001	.707	3/8	5	4	1
1 1/2	11 1/2	.420	.001	.723	3/8	5	4	1
2	11 1/2	.436	.001	.757	3/8	5	4	1
2 1/2	8	.682	.002	1.138	-	6	5	1 1/8
3	8	.766	.002	1.200	-	6	5	1 1/8

Nominal Size	Thickness		A Outside Dia.
	L ₁ Thin	Tolerance Plug	
1/16	.160	.001	1 1/8
1/8	.1615	.001	1 1/8
1/4	.2278	.001	1 3/8
3/8	.240	.001	1 1/2
1/2	.320	.001	1 3/4
3/4	.339	.001	2
1	.400	.001	2 1/2
1 1/4	.420	.001	3
1 1/2	.420	.001	3 1/4
2	.436	.001	3 3/4
2 1/2	.682	.002	4 1/4
3	.766	.002	5

Nominal Size	1560 Plug Gage		1560 Plug Gage w/handle		Handle		
	EDP No.	Price	EDP No.	Price	No.	Price	
1/16	27	701140	83.00	7011401	91.00	1	8.00
1/8	27	701141	54.00	7011411	62.00	2	8.00
1/4	18	701142	61.00	7011421	69.00	3	8.00
3/8	18	701143	69.00	7011431	77.00	3	8.00
1/2	14	701144	77.00	7011441	86.00	4	9.00
3/4	14	701145	92.00	7011451	101.00	4	9.00
1	11-1/2	701146	99.00	7011461	108.00	5	9.00
1-1/4	11-1/2	701147	117.00	7011471	126.00	5	9.00
1-1/2	11-1/2	701148	128.00	7011481	137.00	5	9.00
2	11-1/2	701149	152.00	7011491	161.00	5	9.00
2-1/2	8	701150	183.00	7011501	198.00	6	15.00
3	8	701151	213.00	7011511	228.00	6	15.00

1562 Ring Gage	
EDP No.	Price
701152	138.00
701153	105.00
701154	109.00
701155	124.00
701156	139.00
701157	150.00
701158	176.00
701159	200.00
701160	233.00
701161	278.00
701162	332.00
701163	395.00

When ordering, please use EDP numbers.

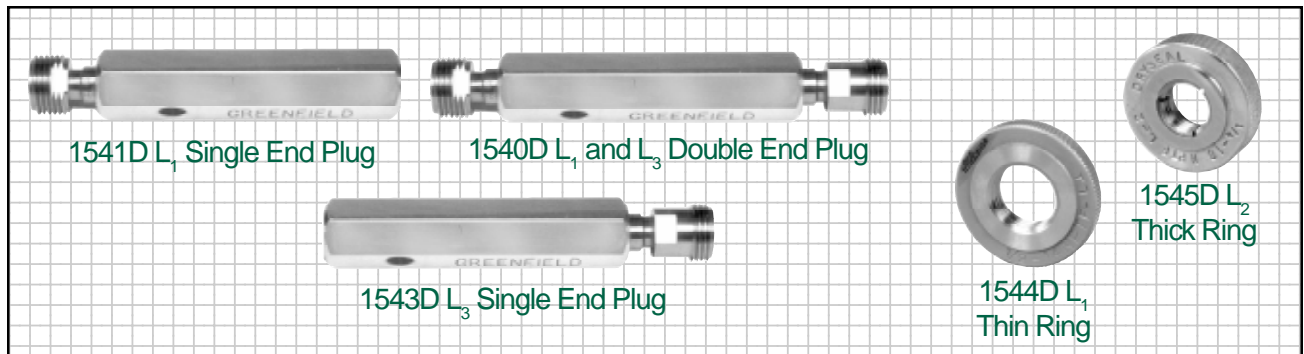

Plug Dimensions

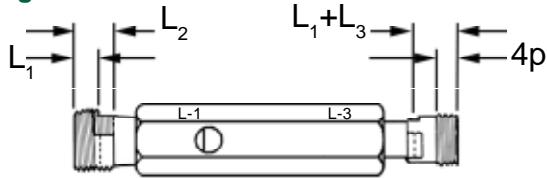

L_1 = Length of engagement in hand tight make up
 L_2 = Length of effective thread (external)
 L_3 = Length of 3 threads beyond L_1 for wrench make up
 $L_1 - p$ = Depth of counterbore from small end of L_2 gage
 Fourth thread on L_3 is for manufacturing and checking purposes only.

Ring Dimensions

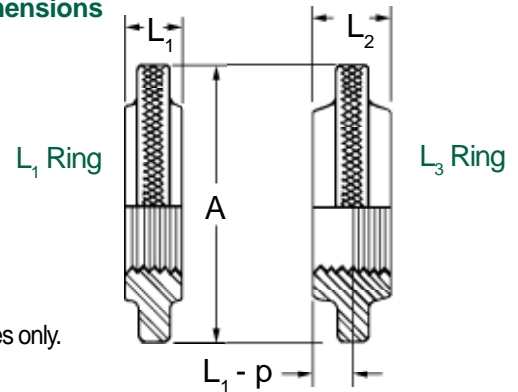

Nominal Size	Length Member L_1 and L_3					
	L_1 To Basic Notch	Tol. Minus	Full Length (Min) L_2	L_1+L_2	Tol. Minus	Handle No.
1/16	.160	.001	.26113	.2711	.001	1
1/8	.1615	.001	.26385	.2726	.001	2
1/4	.2278	.001	.40178	.3945	.001	3
3/8	.240	.001	.40778	.4067	.001	3
1/2	.320	.001	.53371	.5343	.001	4
3/4	.339	.001	.54571	.5533	.001	4
1	.400	.001	.68278	.6609	.001	5
1 1/4	.420	.001	.70678	.6809	.001	5
1 1/2	.420	.001	.72348	.6809	.001	5
2	.436	.001	.75652	.6969	.001	5
2 1/2	.682	.002	1.13750	1.0570	.002	6
3	.766	.002	1.20000	1.1410	.002	6

Nominal Size	A Outside Diameter	Thickness		
		L_1 Thin	L_2 Thick	Tol. Plus
1/16	1 1/8	.160	.26113	.001
1/8	1 1/8	.1615	.26385	.001
1/4	1 3/8	.2278	.40178	.001
3/8	1 1/2	.240	.40778	.001
1/2	1 3/4	.320	.53371	.001
3/4	2	.339	.54571	.001
1	2 1/2	.400	.68278	.001
1 1/4	3	.420	.70678	.001
1 1/2	3 1/4	.420	.72348	.001
2	3 3/4	.436	.75652	.001
2 1/2	4 1/4	.682	1.13750	.002
3	5	.766	1.20000	.002

Nominal Size	1544D L_1 Ring Gage		1545D L_2 Ring Gage		1640D NPTF 6 Step Plug Gage member only w/handle				1642D NPTF 6 Step Ring Gage		
	EDP No.	Price	EDP No.	Price	EDP No.	Price	EDP No.	Price	EDP No.	Price	
1/16	27	701185	145.00	701192	211.00	701178	155.00	7011781	163.00	701199	256.00
1/8	27	701186	120.00	701193	210.00	701179	161.00	7011791	169.00	701200	259.00
1/4	18	701187	124.00	701194	222.00	701180	165.00	7011801	173.00	701201	263.00
3/8	18	701188	141.00	701195	244.00	701181	171.00	7011811	179.00	701202	265.00
1/2	14	701189	149.00	701196	254.00	701182	179.00	7011821	188.00	701203	270.00
3/4	14	701190	172.00	701197	271.00	701183	184.00	7011831	193.00	701204	287.00
1	11-1/2	701191	196.00	701198	295.00	701184	209.00	7011841	218.00	701205	296.00

Nominal Size	1541D L_1 Plug Gage member only w/handle				1543D L_3 Plug Gage member only w/handle				1540D L_1 & L_3 Double End w/ Handle		
	EDP No.	Price	EDP No.	Price	EDP No.	Price	EDP No.	Price	EDP No.	Price	
1/16	27	701164	104.00	7011641	112.00	701171	104.00	7011711	112.00	37401	216.00
1/8	27	701165	85.00	7011651	93.00	701172	85.00	7011721	93.00	37403	178.00
1/4	18	701166	91.00	7011661	99.00	701173	91.00	7011731	99.00	37405	190.00
3/8	18	701167	104.00	7011671	112.00	701174	104.00	7011741	112.00	37407	216.00
1/2	14	701168	123.00	7011681	132.00	701175	123.00	7011751	132.00	37409	255.00
3/4	14	701169	139.00	7011691	148.00	701176	139.00	7011761	148.00	37411	287.00
1	11-1/2	701170	162.00	7011701	171.00	701177	162.00	7011771	171.00	37413	333.00

When ordering, please use EDP numbers.